



## Droplet Size & Velocity Spray Distribution Measurements

Alignment Free

Lightweight

IP66 Spray Rated

Optics Head

True Turnkey  
Operation

Ideal for quality  
control  
applications

## TK Series: PDI-TK1 & TK2

### Turnkey Phase Doppler Interferometer

Artium's Turnkey (TK) line of Phase Doppler Interferometers (PDI) provides the detailed droplet and spray data that only a PDI can deliver without the expertise, training, or infrastructure requirements of a traditional research-grade instrument.

The TK offers permanent alignment and is ready to acquire data right out of the box. The optical heads are sealed and rated IP66 for spray ingress protection. These instruments are designed to be placed directly into a spray with optional purge-air hoods to prevent window fouling and are lightweight enough to easily traverse.

TK instruments utilize the same Advanced Signal Analyzer (ASA) processor and Automated Instrumentation Management System (AIMS) software used in Artium's research-grade Modular PDI systems. This allows TK users access to the powerful processor automation capabilities, data processing, and export capabilities of AIMS. The TK system makes an ideal easy-to-use PDI but may also be used to enhance the measurement capabilities and flexibility of other Artium PDI systems.

The TK line offers two body styles with differing working distances. Both body styles are available in three fixed measurement ranges. Multiple optical heads can be interchanged to optimize instrument sensitivity and diameter size range.

As with all Artium PDI instruments, the TK system is calibrated with a NIST traceable procedure that is valid for the life of the instrument.

## SPECIFICATIONS:

	TK1	TK2
Drop Size Measurement Range	0.5:75 $\mu\text{m}$	
	1:150 $\mu\text{m}$	
	1.5:300 $\mu\text{m}$	1.5:300 $\mu\text{m}$
	3:450 $\mu\text{m}$	3:450 $\mu\text{m}$
Maximum working area (plume or flow size)	70 mm	170 mm
Optical Head Weight	5.8 lbs	6.3 lbs
Laser	Power: 100 mW Wavelength: 532 nm Diode-pumped Solid State (DPSS)	

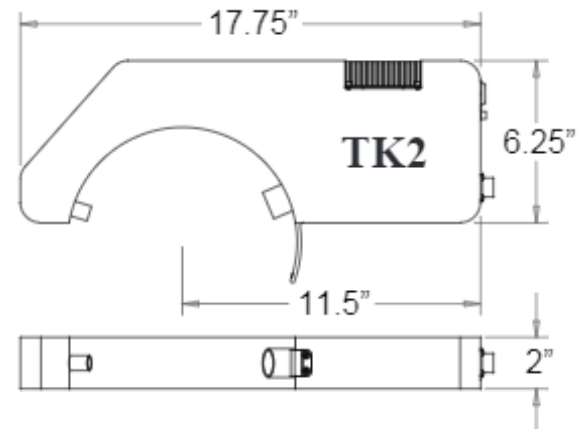
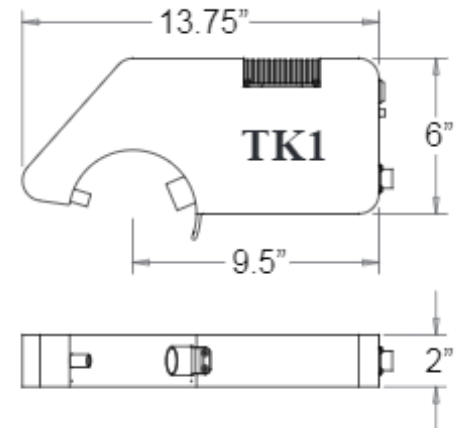

## KEY FEATURES:

- No alignment required
- IP66 spray wash down rated
- Lightweight
- Durable sapphire windows, easy to clean
- NIST Traceable Calibration, no further calibration required for the life of the instrument
- Advanced Signal Analyzer and AIMS software used by research-grade modular PDI instrumentation

## OPTIONAL FEATURES:

- Anti-fogging hoods, prevents droplet accumulation on windows
- Heaters, allow operation in icing conditions

**U.S. Patents:** 7,564,564 B2; 7,788,067 B2; 8,525,093 B2; 7,126,694 B1; 9,390,070 B2; 11,029,241 B2

**EPO Patent:** EP 1,855,081 B1

Our offices, research facilities, and manufacturing plant are located in Sunnyvale, California, where we serve our North American customers. Our distributor partners provide valuable services to our customers in other parts of the world.

AUSTRALIA/  
NEW ZEALAND:  
**Lastek**  
[lastek.com.au](http://lastek.com.au)

CHINA:  
**OPLAN Co. Ltd.**  
[oplanchina.com](http://oplanchina.com)  
+86-10-62623871

EUROPE:  
**LaVision GmbH**  
[lavisoin.com](http://lavisoin.com)  
+49-(0)551-9004-0

INDIA:  
**Tesscorn AeroFluid Inc.**  
[tesscorn-aerofluid.com](http://tesscorn-aerofluid.com)

JAPAN:  
**Seika Digital Image Corporation**  
[seika-di.com](http://seika-di.com)  
+81-3-3405-1288